



B100A

MODEL: B100A

1-Piece Ball Valve

Reduce Port 800WOG

PRODUCT FEATURES

- One-Piece Ball Valve
- Manufacture & Tested to MSS SP-110, API 598
- Various Thread Types Available (NPT, BSP, & Etc.)
- For General Purpose Industrial and Chemical Applications
- Blow-Out Proof Stem

SPECIFICATION

- Round Barstock
- Pressure Rating: 800 PSI WOG
- Size Available: 1/4" to 2"
- Shell Test at 1200 PSI Water and 100 PSI Air
- Seat Test at 880 PSI Water and 100 PSI Air



Keeping Safety
with safe Valves

KSV valves offer positive solutions for all your flow-control applications



B100A

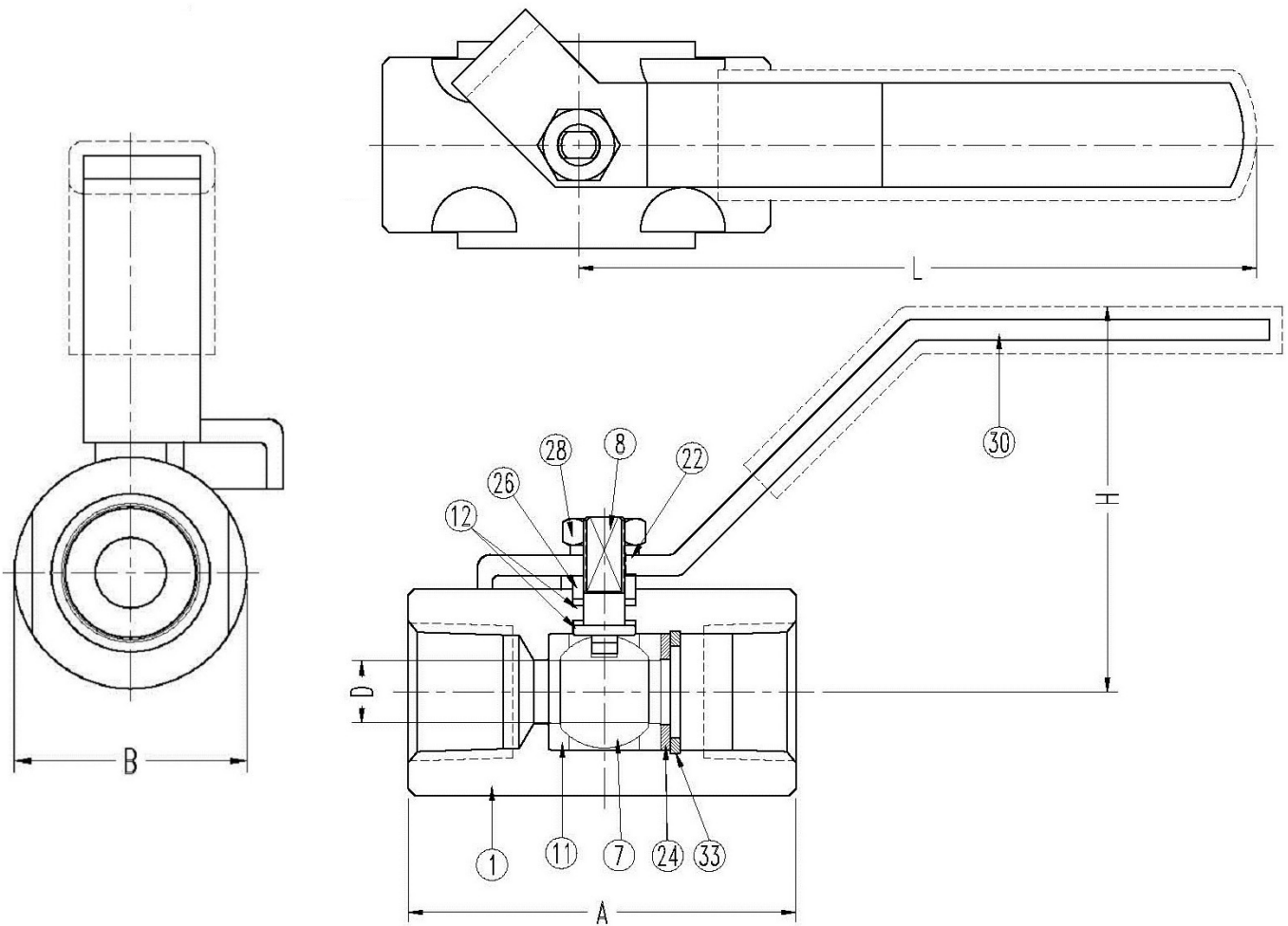

MATERIAL LIST

ITEM	Q'TY	PART NAME	B100A-1	B100A-3
1	1	BODY	SS 316	SS 304
7	1	BALL	SS 316	SS 304
8	1	STEM	SS 316	SS 304
11	2	SEAT	RTFE/TFE	
12	2	STEM SEAL	RTFE/TFE	
22	1	SPRING WASHER	SS 304	
24	1	THRUST WASHER	SS 316	SS 304
26	1	GLAND	SS 304	
28	1	LOCK NUT	SS 304	
30	1	HANDLE	SS 304 / CS 1045	
33	1	SPRING	SS 304	

NPS DN	A	B	D	H	L
1/4"	2.34	1.18	0.30	2.22	4.13
8	59.50	30.00	7.60	56.50	105.00
3/8"	2.34	1.25	0.38	2.26	4.13
10	59.50	31.75	9.70	57.30	105.00
1/2"	2.34	1.25	0.38	2.34	4.13
15	59.50	31.75	9.70	59.40	105.00
3/4"	2.64	1.50	0.50	2.54	4.17
20	67.00	38.00	12.80	64.50	106.00
1"	2.99	1.77	0.67	2.66	4.13
25	76.00	45.00	16.90	67.50	105.00
1-1/4"	3.46	2.17	0.81	3.02	5.88
32	88.00	55.00	20.65	76.60	149.30
1-1/2"	3.86	2.56	1.00	3.20	5.68
40	98.00	65.00	25.50	81.40	144.30
2"	4.41	2.95	1.25	3.43	7.06
50	112.00	75.00	31.85	87.00	179.30



KONG SHENG VALVE IND., CO., LTD.
KONG JIH VALVE IND., CO., LTD.

Office.
 tel. 886-2-2823 9311 fax. 886-2-2823 9319
 Factory.
 tel. 886-4-2681 5268 fax. 886-4-2681 5788
 E-mail: marketing@kstvalve.com