



B260X

MODEL: B260X

2-Piece Ball Valve with "Square Stem" Direct Mounting

Two Piece Ball Valve Full Port 1000WOG

PRODUCT FEATURES

- 2-Piece Square Stem Direct Mounting
- Available in WCB Carbon Steel with 316SS Trim. Or Full CF8M/316 Stainless
- NACE MR-01-75 Compliant
- ISO 5211/EN12116:1995 Industrial Valve Part-turn actuator attachments
- Standard 304SS Latch Lock Handle
- Blow-Out Proof Stem

SPECIFICATION

- Investment Cast Body
- Pressure Rating: 1000PSI WOG
- Steam 150PSI (PTFE Seat)
- Size Available: 1/2" - 2"



R-TFE SEATS
GLASS FILLED TFE

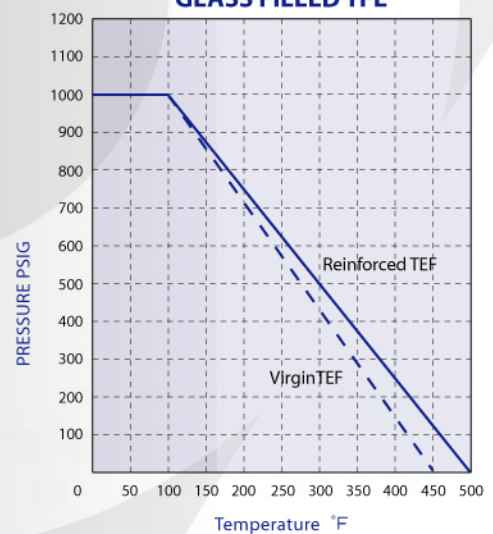

Keeping Safety
with safe Valves

KSV valves offer positive solutions for all your flow-control applications

B260X

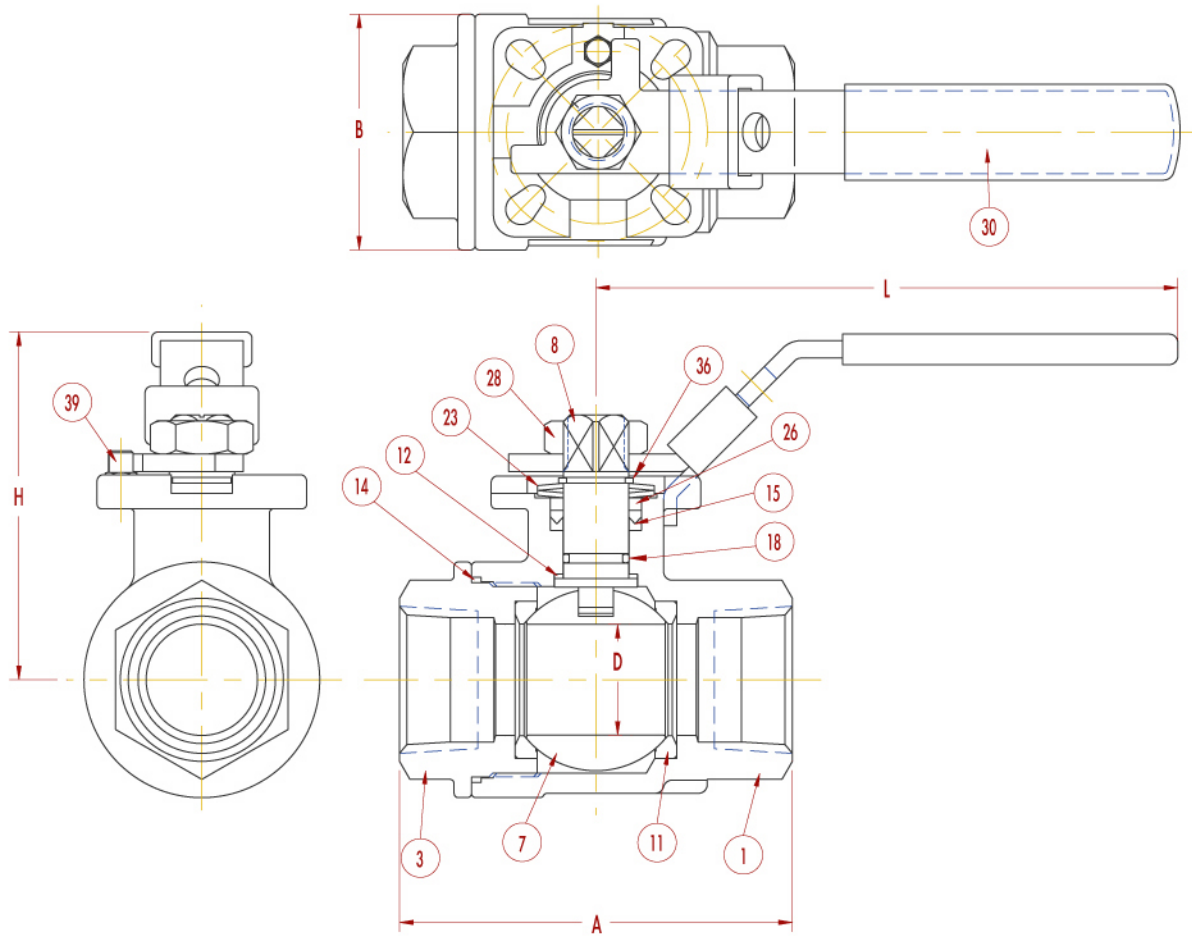

MATERIAL LIST

ITEM	QTY	PART NAME	B260X-1	B260X-3
1	1	BODY	A351-CF8M	A216-WCB
3	1	BODY CAP	A351-CF8M	A216-WCB
7	1	BALL	A351-CF8M	
8	1	STEM	316 SS	
11	2	SEAT	TFE/RTFE	
12	1	STEM SEAL	TFE/RTFE	
14	1	GASKET	RTFE/TFE/VITON	
15	1SET	STEM PACKING	TFE	
18	1	O-RING	VITON	
23	2	BELL WASHER	SK5	
26	1	GLAND	316 SS	
28	1	NUT	304 SS	
30	1	HANDLE	304 SS	
36	1	SNAP RING	304 SS	
39	1	STOP PIN	SS	

DIMENSIONS

NPS DN	IN/MM									
	A	B	D	H	L	WEIGHT KGS/LBS				
1/2"	2.60	1.34	0.56	2.50	4.40	0.43				
15	66.00	34.00	14.20	63.50	112.00	0.95				
3/4"	2.99	1.77	0.81	2.66	4.40	0.64				
20	76.00	45.00	20.50	67.50	112.00	1.41				
1"	3.54	2.13	1.00	3.14	5.87	1.07				
25	90.00	54.00	25.40	79.70	149.00	2.35				
1-1/4"	3.94	2.54	1.25	3.30	5.87	1.50				
32	100.00	64.50	31.80	83.80	149.00	3.30				
1-1/2"	4.41	3.09	1.50	3.60	5.87	2.24				
40	112.00	78.50	38.10	91.50	149.00	4.93				
2"	5.00	3.74	1.97	4.50	7.50	3.69				
50	127.00	95.00	50.00	114.00	190.50	8.12				



KONG SHENG VALVE IND., CO., LTD.
KONG JIH VALVE IND., CO., LTD.

Office.
tel. 886-2-2823 9311 fax. 886-2-2823 9319
Factory.
tel. 886-4-2681 5268 fax. 886-4-2681 5788
E-mail: marketing@kshvalve.com